

H Series Crankshaft

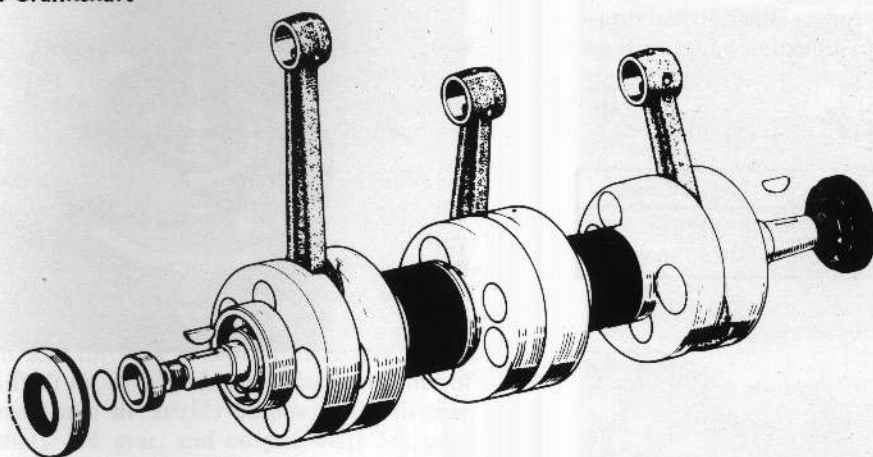

150

Warp Measurement

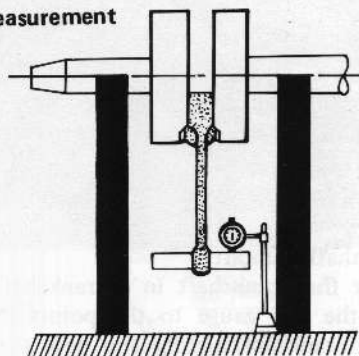

151

1) Disassembly

Lightly tap both ends of the crankshaft with a mallet, and remove it from the upper crankcase.

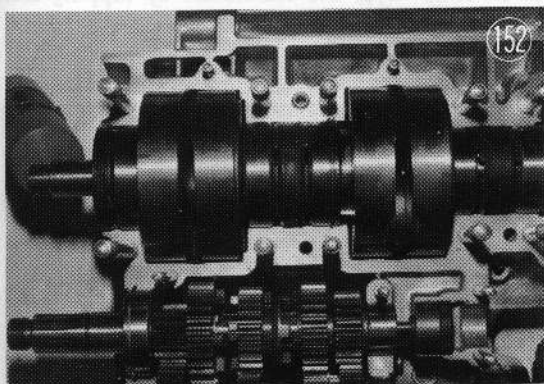

152

2) Inspection

a. Connecting Rod Warp

When the piston, piston rings or cylinder is worn unevenly, or there is a strong slapping sound, the connecting rod is becoming bent at the same time.

To measure rod warp, insert a shaft (arbor) whose diameter is as close as possible to the inside diameter of the connecting rod small end, into the small end of the connecting rod. Set this assembly on blocks over a surface plate, and measure the distance between the plate and each end of the rod with a dial gauge. The difference between the two readings gives an indication of the amount the rod has bent. Also check that the rod has not twisted, by visually ascertaining that the inserted rod and the crankshaft are parallel.

b. Connecting Rod Big End Wear

To ensure smooth rotation of the connecting rod, a certain amount of radial and side clearance is provided at the big end. As the connecting rod, crank pin needle bearing or side washers wear, these clearances increase.

Move the connecting rod up and down as illustrated; the amount of movement equals radial clearance. Note that H2 standard clearance is slightly different (.023-.041 mm) from the table.

Table 16 Radial Clearance

Model	Standard	Limit
H1, H2	.00098 - .00138 in. (0.025 - 0.035 mm)	.0039 in. (0.10 mm)

Big End Radial Clearance

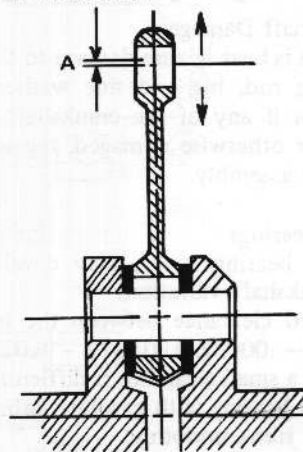

153