

Second Gear

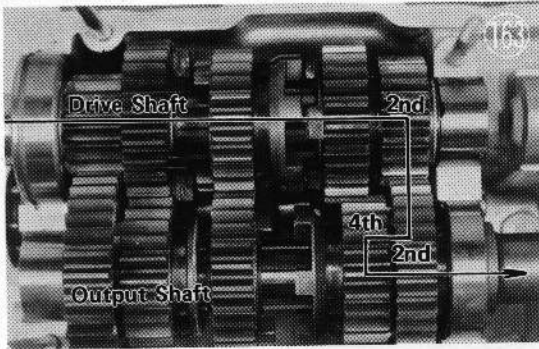

Third Gear

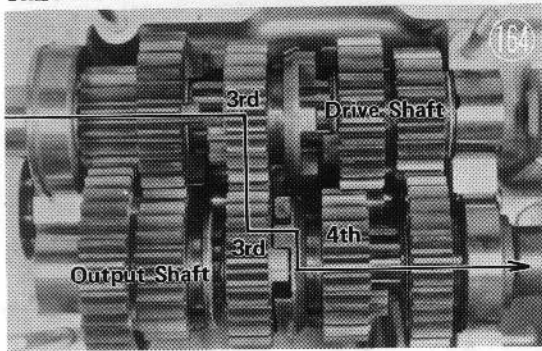

Fourth Gear

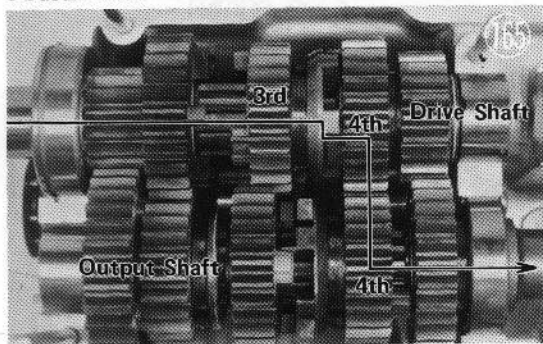

Fifth Gear

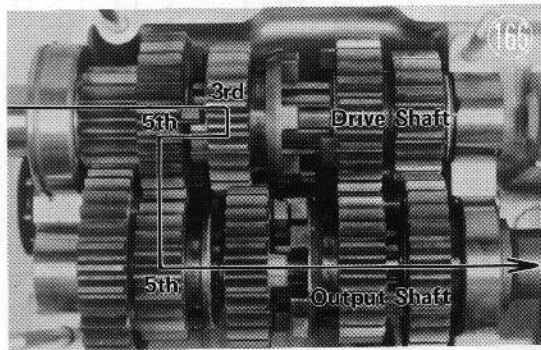

2) Disassembly

a. Drive Shaft · Output Shaft Assemblies

Remove each shaft assembly from the upper crankcase. Take off the circlips and remove the needle bearings and gears.

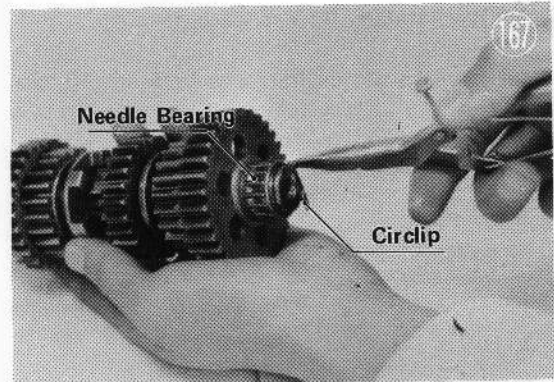

Remove the oil seals and bearings.

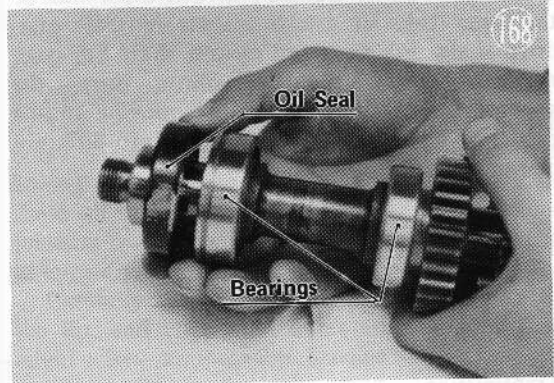

b. Shift Drum

NOTE: The drum lever and positioning plate must first be removed before the shift drum can be taken out.

Straighten the lock washers and pull out the guide pins.

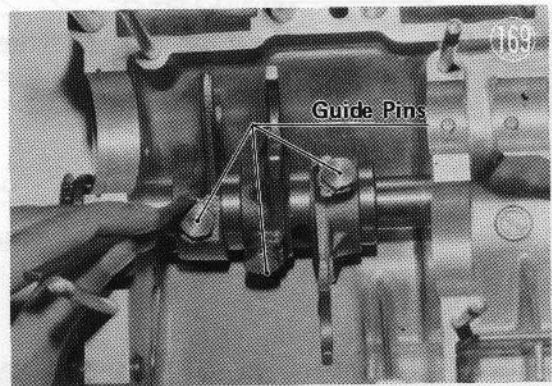

Pull out the shift drum and remove the selector forks.

