

(1) Two leading shoe (front brake)

The two brake shoes fit symmetrically against the two cams as illustrated. When the brake lever is pulled, the two cams are turned simultaneously by the cam lever via the brake cable and lever link, and the cams push the brake shoes against the inside surface of the brake drum. The friction of the shoe against the drum slows down the rotation of the wheel. Since both shoes expand in the direction of wheel rotation this braking method is called the two leading shoe type, and has about one and a half times the braking capacity of the leading trailing type.

Front Brake

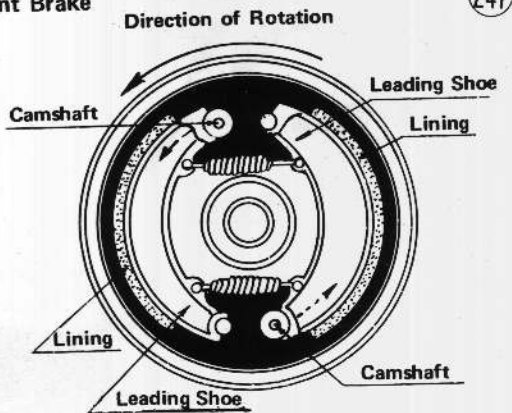

(2) Leading trailing (rear brake)

When the pedal is stepped on, the brake cable pulls the cam lever, which turns the cam shaft that forces the shoes to expand against the drum. At this time one shoe (trailing shoe), expands in direction B opposite drum rotation, and the other shoe (leading shoe) expands in direction A, the direction of drum rotation.

Rear Brake

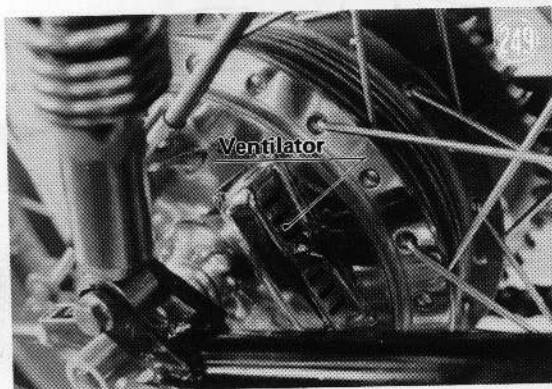
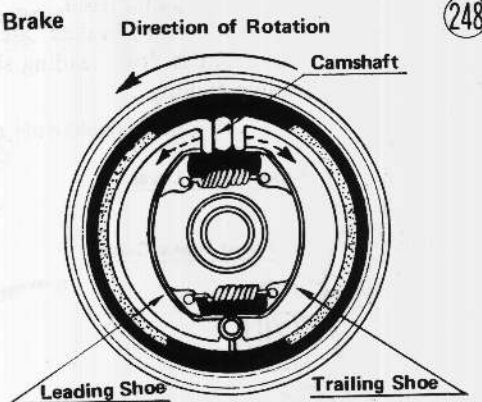

(3) Ventilator

H1 models are equipped with a closable ventilator in the rear brake panel. This can be opened during high speed or prolonged braking to cool the drum and prevent reduction in braking efficiency. During rain or while riding on a dusty road it can be closed to keep out water or dust.

2) Disassembly

a. Bearing and Oil Seals

Each bearing can be removed together with its oil seal (if applicable). Remove the first bearing by hitting the bearing spacer to knock it out. Remove the remaining bearing by setting a rod or starting punch to its inner side and knocking it out. To avoid damage to the surface against which the bearing sits, tap the bearing evenly around its circumference.

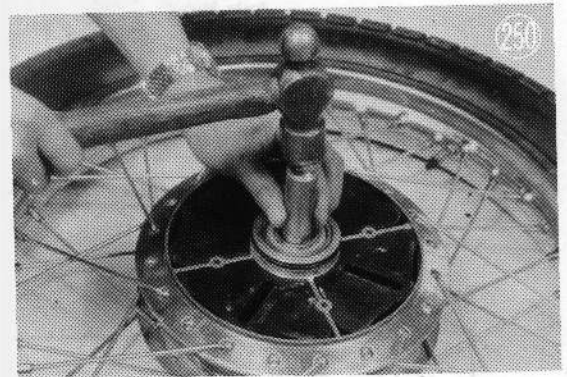

b. Brake Shoes

WARNING: Brake linings contain asbestos fiber. Inhalation of asbestos may cause serious scarring of the lungs and may promote other internal injury and illness, including cancer. Observe the following precautions when handling brake linings:

1. Never blow brake lining dust with compressed air.
2. If any components are to be cleaned, wash with detergent, then immediately discard the cleaning solution and wash your hands.
3. Do not grind any brake lining material unless a ventilation hood is available and properly used.

If the front or rear brake panel is removed, the shoes, cam, cam lever, etc. come out with it. To take the shoes off the front panel, pull up one side first, at right angles to the brake panel. With the rear brakes, pull both shoes straight up off the pivot studs and remove them together. The linings are bonded to the shoe and cannot be removed.

